

CASE STUDY:

INTEGRATED TARGET CONTROL SYSTEM – Real-Time System Legacy Modernization

CLIENT DESCRIPTION:

The China Lake Naval Air Warfare Center Weapons Division (NAWCWD) Target Control Systems Branch is responsible for the engineering and development of air, land, and sea target control systems used in support of training and Test and Evaluation (T&E) operations for the United States Navy.

CTA PROJECT DESCRIPTION:

The Navy's Integrated Target Control System (ITCS) is a Time-Division Multiplexing (TDM), real-time target control system capable of controlling up to 8 independent airborne, water borne or ground based targets over a 250-mile (line of sight) range in support of weapon systems training and T&E operations. The ITCS modernization was an effort begun in the early 1990s to re-host the ground control portion of the existing ITCS (hosted on late 1970s based hardware), to newer, more capable, technologies, in an effort to extend the systems life, and reduce costs, until a Department of Defense (DOD) tri-service system could be developed and deployed. The original ITCS ground control system was written in assembly language, and hosted on Data General Eclipse computers. The modernization project involves the redevelopment of the control software in an HOL environment (ADA, C, C++) emphasizing ease of modification, greater portability and enhanced maintainability through both an object based implementation, and the use of strong data typing to enforce key software design elements, resulting in lower projected long term maintenance costs for the customer. This effort also includes a re-host to multiple, VME based Motorola 68040 single board computers running the VxWorks operating system, using VxMP shared memory object components to support high-speed synchronization and communications between tasks running on separate CPUs. Computer Technology Associates, Inc. (CTA) was approached in 1997, as a successful contractor to the Tactical Air Range Integration Facility (TARIF), to provide software and systems engineering, and program documentation support to this modernization effort. The project has now moved beyond the initial re-host effort, into upgrading other parts of the ITCS system. A key project upgrade effort currently underway, requires the interfacing of the ITCS system to a new tracker system, incorporating Global Positioning System (GPS) data, and operating at a non-harmonic frame rate. Additionally, because of the protracted development effort, a new re-host will be necessary, as the older 68040 products are no longer being supported by hardware and software vendors, who are moving to Power PC based products. The redeveloped HOL software enables the cost-effective and timely execution of this re-host effort.

PROJECT REQUIREMENTS:

Working as a member of a small 3-man software development team CTA has provided needed expertise in Ada, C, and C++ software development in a real-time multi-processor / multi-platform VxWorks based environment, X-windows Graphical User Interface (GUI) development, as well as creation and maintenance of a revision control system to support the development and deployment of the ITCS software system. CTA has additionally, provided hardware technician, and technical documentation support as needed by the customer.

SYSTEM ARCHITECTURE:

The ITCS ground control system is part of the larger Integrated Target Control System (see figure 1.0) composed of the ground based Multiple Drone Control Set (MDCS) and the AN/DKW-3B(V)2 transponder / target interface system which is flown on the target vehicle. The MDCS is further broken into the Local Data Interface Group (LDIG) and the Remote Data Interface Group (RDIG), which are the remote sites and tracker antennas. The modernization project upgrades the components of the Local Data Controllers (LDC), the Operator Interface Controller (OIC), and the System Control Device (SCD) portions of the LDIG.

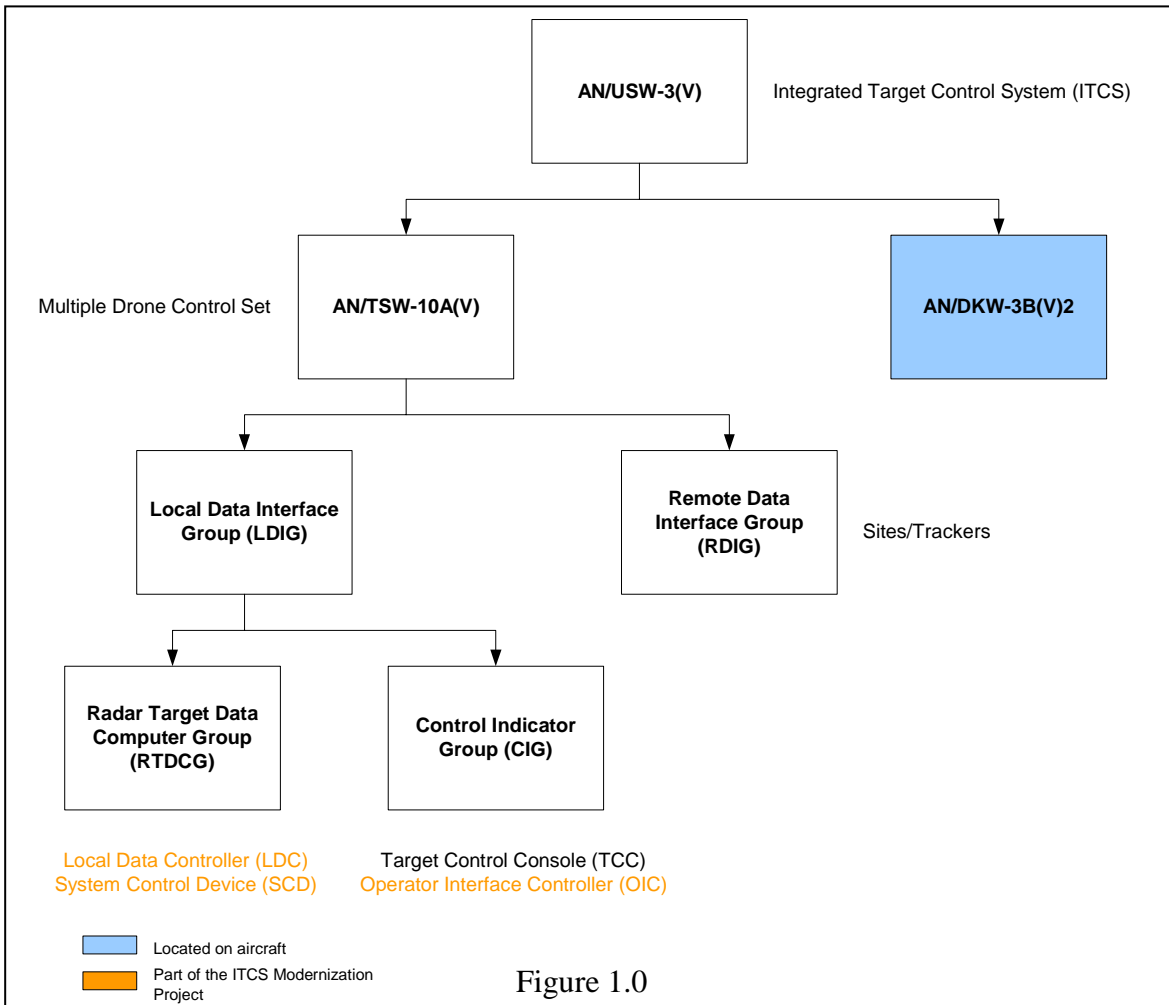

The LDC and OIC components are VME based 68040 multi-processor systems running the VxWorks operating system, while the SCD is hosted on an IBM-PC running Windows 2000 professional. An LDC can support up to 8 OICs, 8 SCDs, and 3 RDIGs (up to 8 trackers) at an operational site (see figure 2.0). The LDC provides a central message passing interface for all system components and external interfaces, along with the 90hz frame synchronization for the entire system, and real-time mission data recording. Each OIC is physically attached to a Target Control Console (TCC), which provides the controls and gauges necessary to operate a single target. Additionally, each OIC can be associated with a Universal Control Console (UCC – full-size cockpit) or Auxiliary Target Control Console (ATCC - used mostly for controlling ship targets). The LDC, OICs and SCDs are interfaced via standard 10Base2 Ethernet.

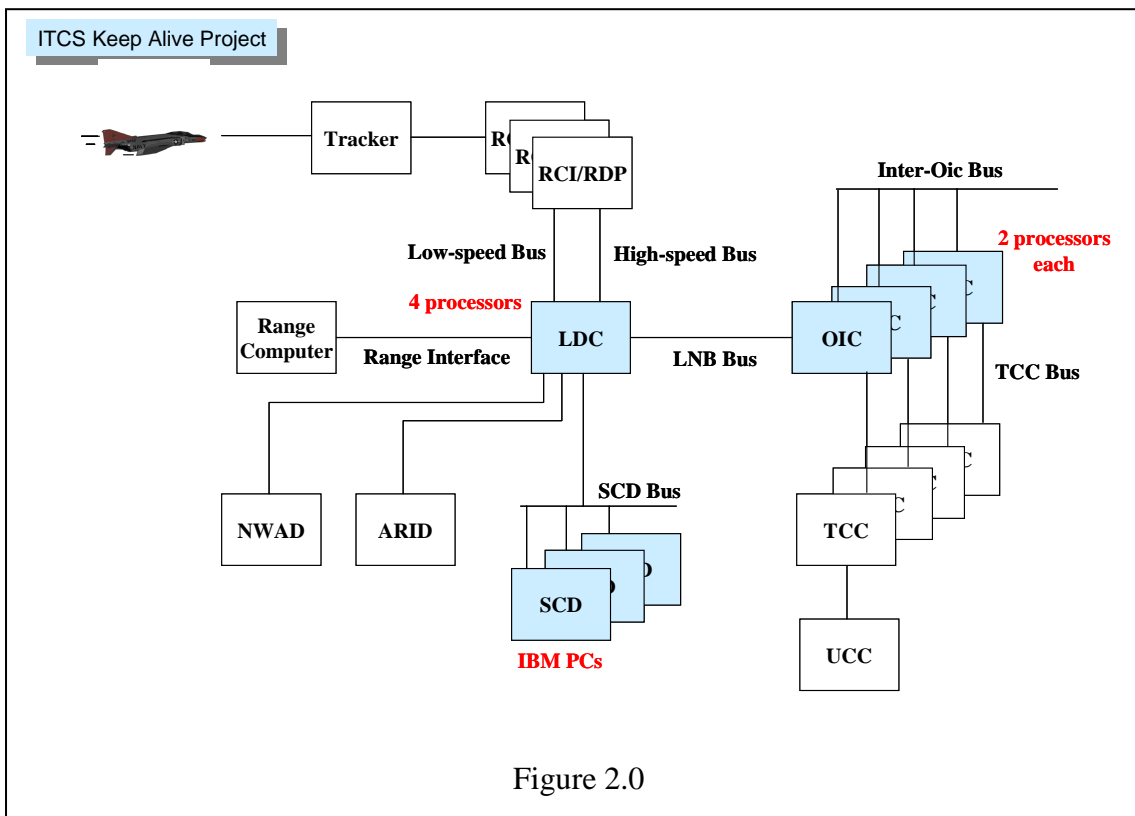

Figure 2.0

The LDC is composed of 4 - 68040 based single board computers integrated through shared memory, mailboxes and semaphores using the VxMP facilities of VxWorks, an IRIG-B time receiver, a custom built Time Slot Synchronizer producing an accurate 90hz pulse synchronized to the 1 second IRIG output, 3 Frame Synchronizer Telemetry Output Interface Boards (FSIO2 – one per site interface), two large capacity hard-disk drives and two streaming tape drives (for real-time mission data recording), and a PCMCIA flash carrier card for initial system loading.

Each OIC is composed of 2 - 68040 single board computers integrated through shared memory, mailboxes and semaphores using the VxMP facilities of VxWorks, 2 X-CEL X-Windows server cards each driving a 21 inch hi-res monitor, a Green Spring VIPC616 IndustryPack carrier board populated with two Systran DIO316I 48 channel digital I/O boards (interfacing the Target Control Console (TCC) hardware), a PCMCIA flash carrier card for initial system loading, and a dual floppy drive.

Each SCD is a standard IBM-PC desktop computer with Ethernet NIC card.

WORK ACCOMPLISHED:

Software/Systems Engineering

Software Engineering

CTA lead the effort to develop and deliver a Software Development Plan and provided needed ADA, C, C++ software development expertise, as a member of the software development team that fielded versions 1.0, 2.0, 2.1 and 2.2 of the ITCS software at the Damneck, VA (VC-6), China Lake, and Point Mugu ranges. This effort included support for the evaluation of new compilers and development environments to replace the current environment that is no longer supported. The new environment is to support the current 68040 processor development, as well as the move to newer Power-PC based development.

CTA also designed and implemented a software revision control system based on the Unix Revision Control System (RCS) utility. This system is used to track both developmental and operational software changes, and plays a significant role in the ITCS system/software change control process. CTA created and delivered a VDD for each of the major software releases fielded.

Systems Engineering

As part of the effort to develop a complete ITCS documentation package, CTA has started the development of an integrated IRS, detailing all system interfaces in a single document. CTA has provided CAD support for the development of complete drawing packages for the new ITCS hardware, and specific site installations.

CTA also provided hardware technician support for the fabrication of the new VME chassis and cabling which are replacing the old Data General hardware.

CTA is currently in the process of providing support for the design and implementation of the ESDL interface to a new generation of sites/trackers, which were originally funded for employment with the new tri-service Target Control System. The current effort is to show the feasibility of interfacing these planned systems to the current ITCS system, as well as implementation of the

interface in anticipation of a successful development effort for producing a tri-service target control system.

Documentation Support

Creation of Operator and Maintenance Manuals

CTA is currently developing both an operator's manual and a maintenance document. This effort has included CTA staff members sitting down with operators and technicians and developing step-by-step procedures for operation and maintenance of the system.

BENEFITS TO CLIENT:

The ITCS modernization effort has taken on added importance to the client due to the non-availability of the planned tri-service replacement system.

CTA involvement with the ITCS modernization program has provided hardware, software, and documentation development expertise for our customer, enabling successful deployment of this mission critical system. The implemented software revision control system has eliminated site installation problems resulting in greater acceptance of the new system at all levels of users, from base commanders, to independent testers, and program management.

The client is now looking forward to continued funding on efforts involving upgrade of other ITCS components, such as: ITCS modernization Phase II (upgrade of the remote sites); Target Control Console (TCC) upgrade; addition of a 3-D tactical display capability; system wide upgrade to newer Power PC single board computers; and replacement of certain critical components with more capable hardware. Additionally, the upgraded system may be used in feasibility testing of other capabilities; most notably a pixel-vector based Automated Visual Landing System with potential use even in commercial aircraft.

CTA's outstanding efforts on this program were recognized by the client through the award of perfect scores to the project team by the Navy's Performance Evaluation Board for Technical, Management, Schedule and Cost performance.